



# Water chillers

AQUACIAT 2

High energy efficiency with  
**R410A**  
 Compact and quiet  
**Scroll** compressors  
 Brazed plate heat exchangers  
 Self adjusting electronic **control system**



Cooling capacity: 20 to 290 kW  
 Heating capacity: 20 to 285 kW



Cooling or heating



Hydraulic pack



Heat recovery



## USE

The **AQUACIAT 2 series LD-LDC-LDH** or **ILD-ILDC-ILDH** water chillers or heaters with air-cooled condensers are medium capacity units particularly adapted for heating and air conditioning applications in the fields of Offices, Healthcare, Industry, Administration, Commercial and Residential buildings.

These standard packaged units are designed for outdoor installation; no particular precautions have to be taken against adverse weather conditions.

An optional XTRAFAN version allows if necessary the possibility of mounting an air duct on the fan(s) discharge in the case of air recycling risk or for an acoustic treatment on site.

To operate in **COOLING** or **HEATING** mode, these units use outside air as the only external source; this permits the evacuation of heat in summer or the supply of thermal energy for heating in winter.

Connected to a heating or cooling floor, to fan coil units or to an air handling unit, the reversible Aquaciat 2 Series **ILD-ILDC-ILDH** permits easy heating and air conditioning of buildings.

Each unit is assembled, electrically wired (control and capacity), charged with refrigerant, and tested in factory.

The installation is very simple and the only operations to be carried out on site are the electrical wiring and water connections.

## RANGE

### AQUACIAT 2 series LD

Cooling only chillers without hydraulic equipment.

### AQUACIAT 2 series LDC - LDH

Cooling only chillers with hydraulic equipment, water pump only, or pump and buffer tank.

### AQUACIAT 2 series ILD

Reversible air/water cooled models without hydraulic equipment.

### AQUACIAT 2 series ILDC - ILDH

Reversible air/water cooled models with hydraulic equipment (circulating water pump only or pump and buffer tank).

### DESCRIPTION

The standard **AQUACIAT 2 series LD-LDC-LDH (cooling only)** or **series ILD-ILDC-ILDH (reversible)** are delivered with the following components:

- air-cooled condenser with propeller fan motor assembly,
  - chilled water evaporator (or hot water condenser on reversible models),
  - capacity control system on chilled or hot water,
  - starting automatic control, electrical compartment:
    - . Power supply : 3~50Hz 400V (+6%/- 10%) + earth
    - . Control circuit: 1~50Hz 230V
- (transformers are mounted on the unit in the standard version),
- cabinet for outdoor installation.



80 to 300

#### ■ Conformity with the EC European directives

- Machines EC 98 / 37
- Electromagnetic EMC 2004/108/CE
- Under pressure equipment DESP EC 97 / 23:
  - category 2 for LD - LDC - LDH 80V à 1100V
  - category 2 for ILD - ILDC - ILDH 80V à 700V
  - category 3 for ILD - ILDC - ILDH 702V à 1100V
- Low voltage 2006/95/CE

#### ■ Conformity to standards

- EN 60-204 , EN 378-2 (NFC15 - 100 France).

### NOMENCLATURE

<b>ILD</b>	>	reversible version	<b>H</b>	>	hydraulic version with pump and buffer tank
<b>LD</b>	>	cooling only model	<b>540</b>	>	size
<b>C</b>	>	hydraulic version with pump	<b>V</b>	>	refrigerant R410A

### STANDARD OR OPTIONAL EQUIPMENT

	LD	LDC-LDH	ILD	ILDC - ILDH
	COOLING ONLY		HEAT PUMP	
3-400V 50hz main supply without neutral with transformer	Std	Std	Std	Std
Coil protective grille	Std ➔ 300	Std ➔ 300	Std ➔ 300	Std ➔ 300
Resilient mounts	Std	Std	Std	Std
Main switch	Std	Std	Std	Std
Water flow switch	Std	Std	Std	Std
Additional potential free contacts board	O	O	O	O
Remote control (Remote console)	O	O	O	O
Phases control system (direction, absence, under & over voltage)	O	O	O	O
Progressive soft start	O	O	O	O
Anti-frost protection	O	O	O	O
All year round operation (min. outdoor temp.: -15°C)	Std	Std	Std	Std
Condenser fan speed control (min. outdoor temp.: -20°C)	O	O	O	O
Partial heat recovery -Desuperheater	O	O	O	O
BLYGOLD coil protective coating	O	O	O	O
Polyurethane fin protective coating	O	O	O	O
Water filter - 800 µm	O	Std	O	Std
Water adjustment kit (manifold, control valve, stop valve)	O	O	O	O
Flexible water connections	O	O	O	O
Twin pump	-	O / 180 ➔ 1100	-	O / 180 ➔ 1100
Additional technical compartment (without equipment)	O / 180 ➔ 300	O / 180 ➔ 300	O / 180 ➔ 300	O / 180 ➔ 300
Electric auxiliary heater kit 15 kW	-	-	O / 80 ➔ 150	O / 80 ➔ 150
Electric auxiliary heater module 15 - 30 - 45 kW	-	-	O / 180 ➔ 300	O / 180 ➔ 300
MULTICONNECT several units management	O	O	O	O
Auxiliary external heater management board (4 stages)	-	-	O	O
XTRAFAN air fans system	O / ➔ 700	O / ➔ 700	O / ➔ 700	O / ➔ 700
Low temperature glycol/water reinforced insulation (0 to -12°C)	O / 350 ➔	O / 350 ➔	O / 350 ➔	O / 350 ➔
LONWORKS communication gateway	O	O	O	O
Handling for container	350 ➔ 1100	350 ➔ 1100	350 ➔ 1100	350 ➔ 1100
Optimised high pressure operation (all-season operation with energy optimisation)	O / 350 ➔ 1100	O / 350 ➔ 1100	-	-
Electronic expansion valve	O / 350 ➔ 1100	O / 350 ➔ 1100	-	-
Total heat recovery	O / 350 ➔ 1100	O / 350 ➔ 1100	-	-

Std: Standard feature

O: Optional equipment

-: Not available

**Note:** Some technical specifications not appearing on the above list can however be quoted on request (consult us)

## COOLING ONLY - TECHNICAL CHARACTERISTICS



LD - LDC - LDH		80V	90V	100V	120V	150V	180V	200V	240V	300V	
Cooling capacity ①	kW	19.7	22.4	26.3	29.9	38.9	46.7	53.1	61.0	76.8	
Power input	kW	6.9	8.1	9	10.6	13.7	14.8	18.1	20.5	27.7	
EER Efficiency ②		2.84	2.78	2.93	2.82	2.84	3.15	2.94	2.97	2.77	
Seasonal efficiency ESEER		3.34	3.25	3.51	3.26	3.28	4.51	4.33	4.02	3.97	
Lw / Lp ③ (High Perf. - HP)	dB(A)	75/43		79/47		80/48		81/49		86/54	
Lw / Lp ③ (Low Noise version - LN)	dB(A)	71/39		75/43		77/45		78/46		82/50	
Compressor		Hermetic SCROLL 2900 rpm									
Starting mode		Direct in series									
Quantity		1				2					
Capacity control	%	100-0				100-50-0					
Refrigerant oil type		Polyolester POE 3MAF (32cst)									
Oil volume	l	2.50	3.25	3.25	3.25	4.14	6.50	6.50	6.50	8.30	
Refrig. circuit number		1									
Refrigerant fluid (GWP)		R410A (1890)									
Refrigerant load	kg	5.3	5.5	7.2	7.3	7.8	13.2	13.5	14.2	14.2	
Electric supply	ph/Hz/V	3-50Hz 400V (+6%/-10%) + Earth									
Unit protection index		IP 44									
Control voltage	ph/Hz/V	1-50Hz 230V (+6%/-10%) - transformer mounted									
Evaporator		Brazed plates type exchanger									
Water content	l	1.78	1.78	2.22	2.22	3.11	3.55	4.22	4.77	7.71	
Chilled water outlet min/max	°C	-12 / +15									
Minimum water flow	m³/h	2.9	2.9	3.6	3.6	5.1	5.8	6.9	7.8	10.4	
Maximum water flow	m³/h	6.7	7.4	9.0	10	13.1	15.4	17.6	20.4	24.5	
Water connections	≥	Male G 1 1/4"		Male G 1 1/2"			Male G 2"				
Maximum pressure (water side)	bar	LD 10 bars / LDC-LDH 4 bars									
Air cooled condenser		Finned heat exchanger									
Fan ≥	mm	710			800						
No. x Motor rated power High Performance series - HP	nb x kW	1x0.5	1x0.5	1x0.9	1x0.9	1x0.9	1x0.9	1x0.9	1x1.7	1x1.7	
No. x Motor rated power Low Noise series - LN	nb x kW	1x0.35	1x0.35	1x0.46	1x0.46	1x0.46	1x0.46	1x0.46	1x1.2	1x1.2	
High Performance air flow - HP	m³/h	10800	10800	16700	16700	15500	16100	16100	24000	24000	
Low Noise air flow - LN	m³/h	8700	8700	10800	10800	9700	10800	10800	18000	18000	
Mini water content (ILD-ILDC)	l	114	130	155	173	229	131	149	173	209	
Water tank content H model	l	100		150			200				
Expansion vessel C & H model	l	6			12						
Standard pump	n°	44	44	44	44	45	40	40	40	41	
Height without mounts	mm	1170			1393			1743			
Standard series length	mm	1995			1995			1995			
C series length	mm	1995			1995			1995			
H series length	mm	1995			1995			2676			
Depth	mm	1055			1055			1055			
Std range weight without charge	kg	326	329	365	367	449	564	570	576	706	
C range weight without charge	kg	344	347	383	385	467	611	614	620	751	
H range weight without charge	kg	369	372	407	409	492	808	811	817	948	
Storage temperature	°C	+ 50°C									

① Capacities of HIGH PERFORMANCE series based on:EUROVENT conditions (EN 14511)

COOLING mode: +12°C/+7°C and condenser air inlet temperature +35°C

② EER in gross values

③ Total Sound power Lw, total sound pressure at 10 m from the unit, in free field, conformity with ISO 3744 norm

④ According to selection.



## ELECTRICAL SPECIFICATIONS

### ■ Standard units (pump not included)

		80V	90V	100V	120V	150V	180V	200V	240V	300V	350V
Electrical supply	ph/Hz/V	3~50Hz 400V (+6%/-10%) + Earth									
Control circuit voltage	ph/Hz/V	1~50Hz 230V (+6%/-10%) - transformer mounted									
Starting current without pump	A	95	111	118	135	198	130	143	149	230	256
Starting current SOFT START option	A	57	66	70	81	118	83	90	104	146	163
Circuit breaker (Neutral condition TN-TT)	kA	15			10		15			10	
Maxi wires section	mm <sup>2</sup>	10			35			70			95
Maxi rated current ①	A	16.8	17.8	22.7	24.8	30.9	33.0	43.4	49.6	60.0	72.0

		400V	500V	540V	600V	700V	702V	800V	900V	1000V	1100V
Electrical supply	ph/Hz/V	3~50Hz 400V (+6%/-10%) + Earth									
Control circuit voltage	ph/Hz/V	1~50Hz 230V (+6%/-10%) - transformer mounted									
Starting current without pump	A	303	320	276	286	325	333	388	440	457	474
Starting current SOFT START option	A	191	209	192	202	237	243	279	317	333	350
Circuit breaker (Neutral condition TN-TT)	kA	10	35	10			50				
Maxi wires section	mm <sup>2</sup>	95					150				
Maxi rated current ①	A	82.0	104.0	110.0	120.0	138	144	161	190	207	224

① Pump rated current not included

### ■ Hydraulic pumps (C and H models)

SINGLE PUMP														
		44	45	40	41	42	43	117	118	119	102	103	105	107
Pump type	n°	44	45	40	41	42	43	117	118	119	102	103	105	107
Mini flow	m <sup>3</sup> /h	1.0	1.9	5.0	6.0	7.0	8.0	15.0	15.0	15.0	20.0	20.0	20.0	20.0
Maxi pressure	mCE	20.6	20.9	17.5	21.5	22.0	24.5	15.5	26.0	39.0	14.5	18.0	26.0	33.0
Maxi flow	m <sup>3</sup> /h	8.0	13.0	19.0	22.5	30.0	30.0	50.0	50.0	50.0	70.0	86.0	74.0	74.0
Mini pressure	mCE	7.3	9.7	8.5	8.0	10.0	14.0	10.0	21.0	31.0	8.0	10.0	19.5	27.0
Main supply	V	3ph~50Hz 400V (+6%/-10%) + Earth												
Rated output	kW	0.55	0.75	0.75	1.1	1.5	1.85	2.2	4.0	7.5	3.0	4.0	5.5	7.5
Maxi rated current	A	1.7	2.1	1.85	2.67	3.9	4.61	4.5	7.8	13.8	6.3	8.0	10.3	13.8

TWIN PUMP												
		2 x 40	2 x 41	2 x 42	2 x 43	217	218	219	202	203	205	207
Pump type	n°	2 x 40	2 x 41	2 x 42	2 x 43	217	218	219	202	203	205	207
Mini flow	m <sup>3</sup> /h	5.0	6.0	7.0	8.0	15.0	15.0	15.0	20.0	20.0	20.0	20.0
Maxi pressure	mCE	17.5	21.5	22.0	24.5	15.5	26.0	39.0	14.5	18.0	26.0	33.0
Maxi flow	m <sup>3</sup> /h	19.0	22.5	30.0	30.0	50.0	50.0	50.0	70.0	86.0	74.0	74.0
Mini pressure	mCE	8.5	8.0	10.0	14.0	10.0	21.0	31.0	8.0	10.0	19.5	27.0
Main supply	V	3ph~50Hz 400V (+6%/-10%) + Earth										
Rated output	kW	0.75	1.1	1.5	1.85	2.2	4.0	7.5	3.0	4.0	5.5	7.5
Maxi rated current	A	1.85	2.67	3.9	4.61	4.5	7.8	13.8	6.3	8.0	10.3	13.8



# Water chillers

## Control functions or safety devices

- Water flow control
- Thermostatic expansion valve
- High and low refrigerant pressure safety devices
- Safety relief valves on refrigerant circuit
- Temperature sensors and pressure transducers
- Chilled water flow switch mounted
- Unit starting sequence,

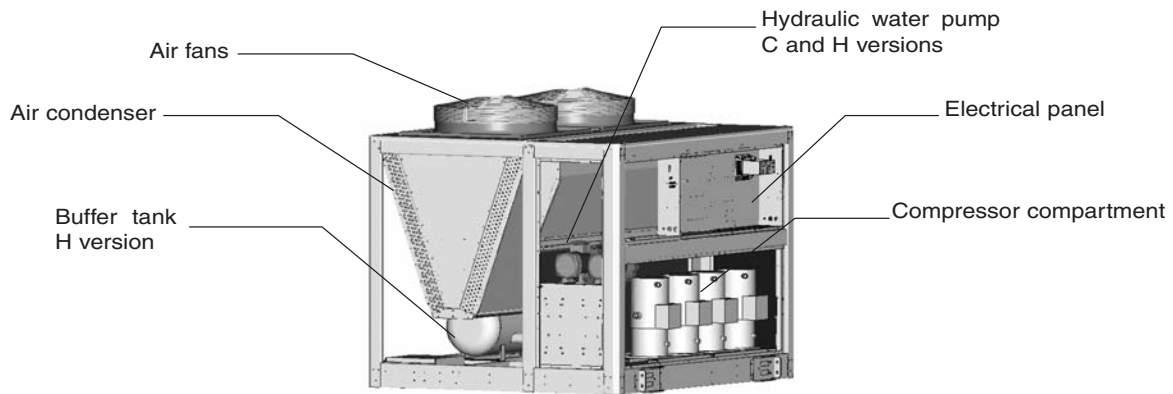

## Electrical box

The electrical box is fully wired and contains all the electric components and the control process unit (CPU) board. It controls all the functions of the machine and allows operation monitoring, adjustment of the water temperature settings, or the interface with an external managing system.

The electrical box includes:

- Power and control circuit
- Wiring numbering
- Main safety circuit breaker on front panel with handle
- Control circuit transformer
- Protection circuit breakers on power and control circuits
- Compressor motor contactor(s)
- Main earthing
- Microprocessor electronic control system
- Free contacts for remote information or alarms.

## ELECTRONIC CONTROL SYSTEM



### Connect 2

CIAT microprocessor and CPU electronic control system with centralized controls and monitoring of internal operating status.

### Includes:

- Run, Stop, Reset or Remote control functions,
- COOLING or HEATING mode selection switch,
- Output. RS485 output for BMS control (ModBus-JBus),
  - . Additional voltage free output adapter board ,
  - . Adapter for remote control (optional).
- Analogical multi-language LCD screen and LED indicators,

### Functions:

- Monitoring of operation information by:

- . direct display of messages in different languages
- . direct display of temperatures and pressures
- Global compressors control with starting sequence, counting and equalization of compressors running times
- Auto-adaptive and advanced functions with a control system adjustment on the parameters drift
- Capacity stage control system on multi compressors as a function of the cooling or heating requirements on the water temperatures
- Control of the internal operating parameters
- Second setting point control
- Direct display of water temperatures and pressures
- Diagnosis of operating status and faults:
  - HP/LP, water flow, compressor motor(s), anti-frost
- Anti-short cycle protection
- Remote management and remote control
- Master/slave control of two units on the same water loop with alternation of the master unit and the slave unit based on the running times.
- Setpoint adjustable via a 4-20 mA signal
- Weekly schedules

## OPTIONAL EQUIPMENT (KIT FOR ON-SITE MOUNTING)

### Main options

- Additional potential free contact boards,
- Remote control box,
- Phase control = rotation direction, phase absence, under and over voltage (factory mounted size 350 to 1100),
- SOFT START (factory mounted size 350 to 1100),
- Anti-freeze protection,
- Fan speed control (factory mounted for 350 to 1100 sizes),
- Water filter 800 microns as standard equipment on LD-LDC-LDH or ILDC-ILDH, and optional accessory on LD-ILD,
- Evaporator and condenser flexible connections,
- Water adjustment kit including pressure gauge manifold, control valve and stop valve,
- Twin pump on sizes 180 to 1100 (factory mounted for 350 to 1100 models).
- 15 kW extra heater kit (ILD, ILDC, ILDH 80 to 150)
- Extra heater MODULE kit 15-30-45-60 kW (ILD, ILDC, ILDH 180 to 300)
- MULTICONNECT management up to 8 units.
- Management 4 extra heater
- LONWORKS protocol (gateway)
- Handling for container (350 to 1100)



## SOUND LEVELS

The **AQUACIAT 2** range design integrates the "noiseless" assembly technology for attenuation of vibrations and sound power sources:

- Scroll compressor(s) located away from the air flow
- Scroll compressor(s) mounted on antivibration mounts
- Piping dissociated from the unit structure
- Low speed fan(s)
- Automatic air flow adjustment
- Resilient mounts to be positioned between the ground and the unit as standard equipment

## HIGH PERFORMANCES - HP

### ■ Sound power levels ref $2 \times 10^{-12}$ Pa $\pm 3$ dB

AQUACIAT	SOUND POWER LEVEL SPECTRUM (dB)														Lw global level dB(A)	
	125 Hz		250 Hz		500 Hz		1000 Hz		2000 Hz		4000 Hz		8000 Hz			
	LD	ILD	LD	ILD	LD	ILD	LD	ILD	LD	ILD	LD	ILD	LD	ILD	LD	ILD
80	78		73		72		72		65		60		54		75	
90	78		73		72		72		65		60		54		75	
100	80		79		76		76		70		64		57		79	
120	80		79		76		76		70		64		57		79	
150	79		81		79		76		69		62		56		80	
180	83		83		78		77		70		66		63		81	
200	81		80		78		77		70		64		60		81	
240	88		88		81		82		76		70		65		86	
300	84		90		85		85		79		72		66		89	
350	83		85		87		85		82		75		68		89	
400	83		85		87		86		82		76		69		90	
500	89		86		86		87		83		77		73		90	
540	84		87		88		86		83		76		70		90	
600	84		87		89		87		83		76		70		91	
700	84		87		89		87		83		76		70		91	
702	88	90	89	93	86	90	86	88	80	81	74	73	69	68	89	92
800	88	90	89	93	86	90	86	88	81	81	75	74	69	68	90	92
900	88	90	89	93	86	90	86	88	80	80	75	74	69	68	90	92
1000	88	90	89	93	86	90	86	88	80	81	75	74	69	68	90	92
1100	88	90	89	93	86	90	86	88	81	81	75	74	69	68	90	92

### ■ Sound pressure levels ref $2 \times 10^{-5}$ Pa $\pm 3$ dB

Measuring conditions: in free field, 10 metres from the unit, 1.50 metres from the ground, directivity 2

AQUACIAT	SOUND PRESSURE LEVEL SPECTRUM (dB)														Lp global level dB(A)	
	125 Hz		250 Hz		500 Hz		1000 Hz		2000 Hz		4000 Hz		8000 Hz			
	LD	ILD	LD	ILD	LD	ILD	LD	ILD	LD	ILD	LD	ILD	LD	ILD	LD	ILD
80	46		41		40		40		33		28		22		43	
90	46		41		40		40		33		28		22		43	
100	48		47		44		44		38		32		25		47	
120	48		47		44		44		38		32		25		47	
150	47		49		47		44		37		30		24		48	
180	51		51		46		45		38		34		31		49	
200	49		48		46		45		38		32		28		49	
240	56		56		49		50		44		38		33		54	
300	52		58		53		53		47		40		34		57	
350	51		53		55		53		50		43		36		57	
400	51		53		55		54		50		44		37		58	
500	57		54		54		55		51		45		41		58	
540	52		55		56		54		51		44		38		58	
600	52		55		57		55		51		44		38		59	
700	52		55		57		55		51		44		38		59	
702	56	58	57	61	54	58	54	56	48	49	42	41	37	36	57	60
800	56	58	57	61	54	58	54	56	49	49	43	42	37	36	58	60
900	56	58	57	61	54	58	54	56	48	49	43	42	37	36	58	60
1000	56	58	57	61	54	58	54	56	48	49	43	42	37	36	58	60
1100	56	58	57	61	54	58	54	56	49	49	43	42	37	36	58	60

**NOTE:** Acoustic pressure levels depend on the installation conditions and consequently are only given as an indication.

Only the sound power levels are comparable and certified.

Compliance with ISO 3744 standard  $L_p = L_w - 10 \log S$



## XTRAFAN FAN SYSTEM (OPTIONAL EQUIPMENT)

AquaCiat2 units 80V to 700V models, for chillers only LD-LDC-LDH series or reversible HEAT PUMPS ILD-ILDC-ILDH series, can be equipped with an XTRAFAN option.

In comparison with standard electric motors controlled by a traditional variator of frequency, this type of electric motor with electronic poles switching equipment and permanent magnet rotors, is characterized by excellent mechanical efficiency and a particularly low noise level, regardless of the load on the shaft.

### Main description

The XTRAFAN option offers a broad range of functions allowing for particularly flexible installation conditions, notably:

- the possibility of being installed in a cramped space, for example on a terrace surrounded by walls, where only a discharge with a static pressure from 100 to 200 Pascals in a duct allows a use without recycling or mixing air to the condenser intake,
- the installation in a particularly noise-sensitive urban environment, where only a suitable sound trap adapted to the air discharge can allow operation,
- the guarantee of obtaining continued operation during temperature peaks in hot climates such as the Middle East, thanks to an "over-boost" function of the condenser fan speed,
- an auto-adjustable speed variation function allowing a highly protected "all season" operation in cooling mode for the industrial process including rigorous winter periods with an external temperature of -20°C,
- the possibility of precisely adjusting on site the fan speed "just enough" to obtain an optimal air discharge pressure, or a maximum noise level tolerated by the environment of the machine,
- an improvement in terms of the EER efficiency and the electrical consumption of the chiller in cooling mode, directly proportional to the refrigerating load requested by the installation.

### Technical specifications and operating range

The XTRAFAN option allows the user to chose one of three possible operating functions of the machine:

- a fortified running of the chiller thanks to the "over boost" fan function in free discharge, in order to extend on full load the outside temperature range from +46 to +50°C,
- reaching an intermediate available static pressure of 100 to 125 Pa with the rated air flow, allowing a duct air discharge at the condenser outlet in order to avoid fan recycling phenomena,
- reaching a maximum static pressure from 130 to 200 Pa according to models at the air discharge with a low air flow, recommended for on-site installation of a sound trap on the air discharge.

	HIGH outside temperature Fan over boost			RATED Static pressure			MAXIMUM Static pressure		
	Available pressure Pa	Air flow m³/h	Operation limits °C	Available pressure Pa	Air flow m³/h	Operation limits °C	Available pressure Pa	Air flow m³/h	Operation limits °C
80V - 90V	0	16500	Operation limits widened to +46°C to +50°C	125	10400	Idem PERFORMANCE mode	160	9000	Idem LOW NOISE mode
100V - 120V		23800		150	17000		200	12000	
150V		23000		150	16200		200	12000	
180 - 200V		23500		150	16500		200	12000	
240V - 300V		26000		100	22100		200	17000	
350V - 400V		50400		100	42000		200	34000	
500V		52000		100	40000		200	34000	
540V - 600V		61200		100	48000		130	43000	
700V		58000		100	46000		130	43000	





# Water chillers

## COOLING CAPACITIES

### COOLING ONLY models

LD LDC LDH	Evaporator water outlet temperature °C	INLET AIR TEMPERATURE AT THE CONDENSER °C										
		25		30		35		40		46		
		Pf kW	Pa kW	Pf kW	Pa kW	Pf kW	Pa kW	Pf kW	Pa kW	Pf kW	Pa kW	
<b>80V</b>	Glycol water	-12	10,9	4,9	10,1	5,4	9,3	6,0	8,5	6,6		
		-10	11,8	4,9	11,0	5,4	10,2	6,0	9,3	6,7		
		-8	12,8	5,0	11,9	5,5	11,1	6,1	10,2	6,8		
		-4	14,9	5,1	13,9	5,7	13,0	6,2	12,0	6,9		
		0	17,1	5,3	16,1	5,8	15,1	6,4	14,0	7,1	12,6	8,0
	Pure water	5	20,8	5,5	19,6	6,1	18,4	6,7	17,1	7,4	15,5	8,2
		7	22,3	5,7	21,0	6,2	19,7	6,94	18,4	7,5	16,7	8,3
		12	25,8	5,9	24,4	6,5	22,9	7,1	21,4	7,8	19,5	8,6
15		28,1	6,1	26,6	6,7	25,0	7,3	23,4	8,0	21,4	8,8	
<b>90V</b>	Glycol water	-12	12,4	5,5	11,6	6,2	10,7	6,8	9,6	7,6		
		-10	13,5	5,6	12,7	6,2	11,7	6,9	10,6	7,7		
		-8	14,6	5,7	13,7	6,3	12,7	7,0	11,7	7,8		
		-4	16,9	5,9	15,9	6,5	14,9	7,2	13,8	8,0		
		0	19,5	6,1	18,4	6,7	17,3	7,4	16,1	8,2		
	Pure water	5	23,5	6,5	22,2	7,0	20,9	7,7	19,6	8,5	17,3	9,6
		7	25,1	6,6	23,8	7,2	22,4	8,06	21,0	8,6	18,6	9,8
		12	29,0	7,0	27,4	7,6	25,9	8,2	24,3	9,0	21,6	10,2
15		31,5	7,2	29,8	7,8	28,1	8,5	26,3	9,3	23,5	10,5	
<b>100V</b>	Glycol water	-12	14,8	6,4	13,8	7,1	12,8	7,9	11,7	8,7		
		-10	16,1	6,4	15,1	7,2	14,0	8,0	12,9	8,8		
		-8	17,4	6,5	16,3	7,3	15,2	8,1	14,0	8,9		
		-4	20,2	6,7	19,1	7,4	17,8	8,2	16,5	9,1		
		0	23,3	6,9	22,0	7,6	20,6	8,4	19,1	9,3	17,3	10,4
	Pure water	5	27,7	7,2	26,1	7,9	24,5	8,7	22,9	9,5	20,8	10,7
		7	29,5	7,3	28,0	8,0	26,3	8,98	24,6	9,7	22,4	10,8
		12	34,3	7,6	32,5	8,3	30,7	9,1	28,7	10,0	26,2	11,1
15		37,4	7,8	35,5	8,5	33,4	9,3	31,3	10,2	28,7	11,3	
<b>120V</b>	Glycol water	-12	16,6	7,7	15,5	8,4	14,4	9,2	13,1	10,2		
		-10	18,1	7,8	16,9	8,5	15,7	9,3	14,4	10,3		
		-8	19,6	7,9	18,3	8,6	17,0	9,5	15,7	10,4		
		-4	22,7	8,1	21,3	8,8	19,9	9,7	18,4	10,6		
		0	26,1	8,3	24,6	9,0	23,0	9,9	21,4	10,8	19,3	12,1
	Pure water	5	31,5	8,7	29,7	9,4	27,9	10,3	26,0	11,2	23,6	12,4
		7	33,7	8,8	31,8	9,6	29,9	10,6	27,9	11,4	25,4	12,6
		12	39,0	9,2	36,9	10,0	34,7	10,8	32,4	11,8	29,6	13,0
15		42,4	9,5	40,2	10,2	37,8	11,1	35,3	12,0	32,4	13,2	
<b>150V</b>	Glycol water	-12	21,8	9,5	20,6	10,4	19,4	11,2	18,0	12,2		
		-10	23,6	9,6	22,4	10,5	21,0	11,4	19,6	12,4		
		-8	25,4	9,8	24,2	10,7	22,8	11,7	21,2	12,7		
		-4	29,4	10,1	27,9	11,1	26,3	12,1	24,6	13,2		
		0	33,7	10,5	32,0	11,4	30,3	12,5	28,3	13,7	25,9	15,1
	Pure water	5	40,5	11,0	38,5	12,0	36,4	13,1	34,1	14,3	31,3	15,8
		7	43,5	11,2	41,2	12,3	38,9	13,7	36,5	14,6	33,6	16,1
		12	50,2	11,8	47,7	12,9	45,0	14,0	42,2	15,2	39,0	16,7
15		54,6	12,2	51,8	13,3	48,9	14,4	45,9	15,7	42,5	17,2	
<b>180V</b>	Glycol water	-12	25,4	10,5	23,9	11,7	22,0	12,9	20,0	14,4		
		-10	27,6	10,7	26,0	11,8	24,1	13,0	22,1	14,5		
		-8	29,8	10,8	28,2	11,9	26,3	13,2	24,3	14,6		
		-4	34,6	11,0	32,9	12,2	30,9	13,4	28,7	14,9		
		0	40,0	11,3	38,0	12,5	35,8	13,7	33,4	15,2	30,1	17,3
	Pure water	5	48,4	11,8	46,1	13,0	43,5	14,3	40,8	15,7	37,4	17,6
		7	52,0	12,1	49,4	13,2	46,7	14,8	43,8	15,9	40,2	17,9
		12	60,4	12,7	57,3	13,9	54,2	15,2	51,0	16,6	47,0	18,5
15		65,6	13,2	62,3	14,4	58,9	15,6	55,5	17,0	51,2	18,9	

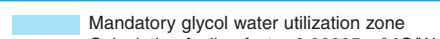
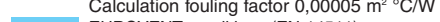
Pf: Cooling capacity valid for delta T according to operating limits  
 Pa: Power input  
 Pc: Heating capacity valid for delta T according to operating limits

 Mandatory glycol water utilization zone  
 Calculation fouling factor 0,00005 m<sup>2</sup> °C/W  
 EUROVENT conditions (EN 14511)

AQUACIAT 2

R410A

HIGH PERFORMANCES - HP